



**INSTALLATION
MANUAL ANNEX
OF STANDARD
SOLAR MODULES**

ANNEX A: ALTERNATIVE MOUNTING METHODS	 3
MOUNTING METHOD A: CLAMPING	 3
MOUNTING METHOD B: INSERTION SYSTEMS	 13
MOUNTING METHOD C: CENTER MOUNTING METHOD WITH THIRD PARTY TRACKER	 15
ANNEX B: ALTERNATIVE GROUNDING METHODS	 16
ANNEX C: MECHANICAL AND ELECTRICAL RATINGS	 18
ANNEX D: MODULE CLEANING GUIDELINES	 21
AMENDED EDITIONS AND DATES	 22
INSTALLATION MANUAL DISCLAIMER	 23

ANNEX A: ALTERNATIVE MOUNTING METHODS

All the basic requirements of the main installation manual should apply to the alternative mounting methods, unless otherwise specified.

The loads described in this manual corresponds to test loads. For calculating the equivalent maximum authorized design loads, a safety factor of 1.5 should be applied as per IEC 61215-2 and UL 1703 standards.

Project design loads depend on construction, applicable standards, location and local climate. Determination of the design loads is the responsibility of the racking suppliers or professional engineers. For detailed information, please follow local structural code or contact your professional structural engineer.

MOUNTING METHOD A CLAMPING

- The mounting method has been qualified by Canadian Solar Inc. and certified by VDE and CSA.
- Top or bottom clamping methods will vary and are dependent on the mounting structures. Please follow the mounting guidelines recommended by the mounting system supplier.
- Each module must be securely fastened at a minimum of four points on two opposite sides. The clamps should be positioned according to the authorized position ranges defined in table A.
- Install and tighten the module clamps to the mounting rails using the torque stated by the mounting hardware manufacturer. M8X1.25-Grade8.8 bolt and nut are used for this clamping method. Tightening torques should be within 17~23 Nm (12.5~17.0 ft-lbs) for M8 (5 / 16"-18 Grade B7) coarse thread bolts, depending on the bolt class. For the bolt grade, the technical guideline from the fastener suppliers need to be followed. Different recommendations from specific clamping hardware suppliers should prevail.
- The system designer and installer are responsible for load calculations and for proper design of support structure.

- Canadian Solar Inc.'s warranty may be void in cases where improper clamps or unsuitable installation methods are found. When installing inter-modules or end-type clamps, please take the following measures into account:

- ① Do not bend the module frame
- ② Do not touch or cast shadows on the front glass
- ③ Do not damage the surface of the frame (to the exception of the clamps with bonding pins)
- ④ Ensure the clamps overlap the module frame by at least 5 mm (0.2 in)
- ⑤ Ensure the clamps overlap length is at least 40 mm (1.57 in)
- ⑥ Ensure the clamp's thickness is at least 3 mm

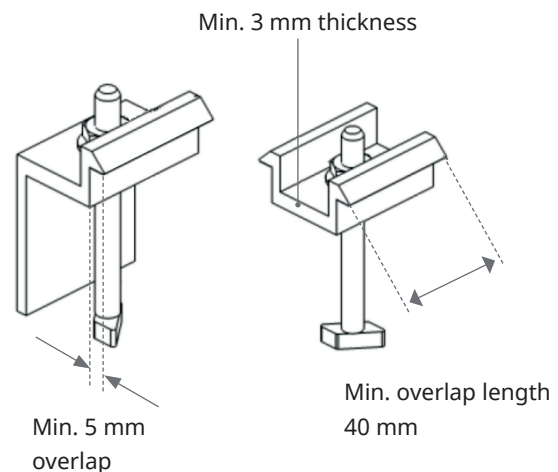

- Clamp material should be anodized aluminum alloy or stainless steel.
- Clamp positions are of crucial importance for the reliability of the installation. The clamp centerlines must only be positioned within the ranges indicated in table A, depending on the configuration and load.
- For configurations where the mounting rails run parallel to the frame, precautions should be taken to ensure the bottom flange of the module frame overlaps the rail by 15 mm (0.59 in) or more.

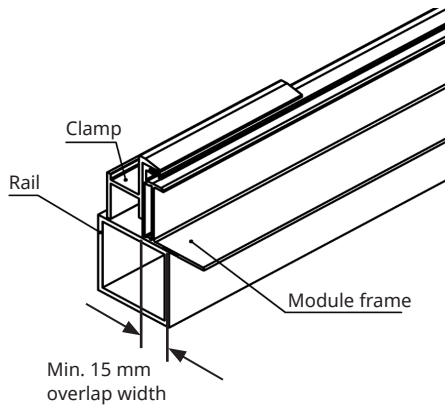
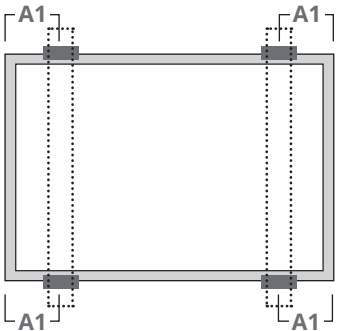
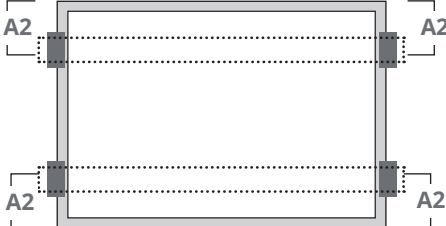
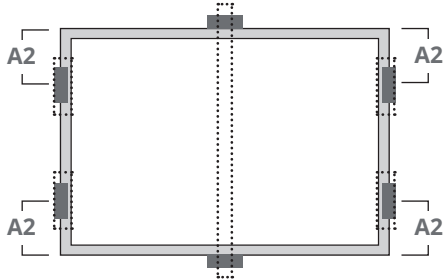
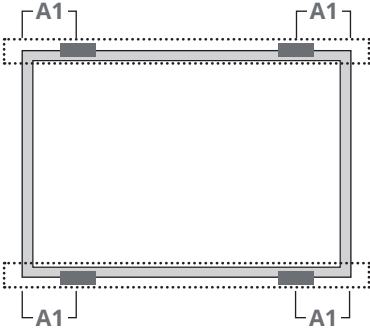
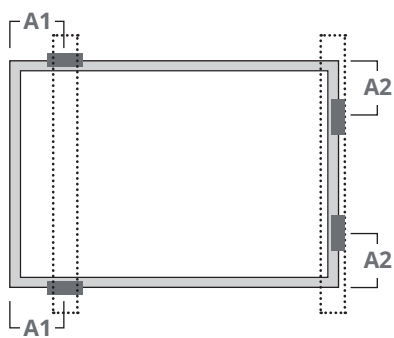

Table A
CS6X-P and CS6X-M

 <p>Use four clamps on the long side. Mounting rails run perpendicular to the long side frame.</p>	 <p>Use four clamps on the short side. Mounting rails run parallel to the long side frame.</p>
<p>A1 range = (340 – 550) mm Maximum Load: Uplift load \leq 2400 Pa Downforce load \leq 2400 Pa</p>	<p>A2 range = (200 – 250) mm Maximum Load: Uplift load \leq 1800 Pa Downforce load \leq 2400 Pa</p>
<p>A1 range = (410 – 490) mm Maximum Load: Uplift load \leq 2400 Pa Downforce load \leq 5400 Pa</p>	 <p>Use four clamps on the short side and two clamps on the long side. An additional support bar should be placed below the center of the module.</p> <p>A2 range = (200 – 250) mm Maximum Load: Uplift load \leq 2400 Pa Downforce load \leq 5400 Pa</p>
 <p>Use four clamps on the long side. Mounting rails run parallel to the long side frame.</p>	<p>A1 range = (410 – 490) mm Maximum Load: Uplift load \leq 2400 Pa Downforce load \leq 5400 Pa</p>



Use two clamps on the long side and two clamps on the short side.

A1 range = (300 – 550) mm
 A2 range = (200 – 250) mm
 Maximum Load:
 Uplift load \leq 2400 Pa
 Downforce load \leq 2400 Pa

CS6U-P and CS6U-M

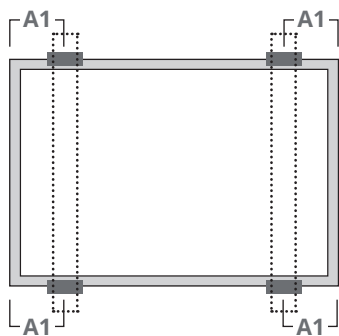

Use four clamps on the long side. Mounting rails run perpendicularly to the long side frame.

A1 range = (340 – 550) mm
 Maximum Load:
 Uplift load \leq 2400 Pa
 Downforce load \leq 2400 Pa

A1 range = (410 – 490) mm
 Maximum Load:
 Uplift load \leq 2400 Pa
 Downforce load \leq 5400 Pa

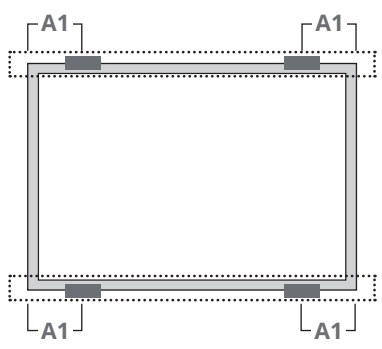

Use four clamps on the long side. Mounting rails run parallel to the long side frame.

A1 range = (410 – 490) mm
 Maximum Load:
 Uplift load ≤ 2400 Pa
 Downforce load ≤ 5400 Pa

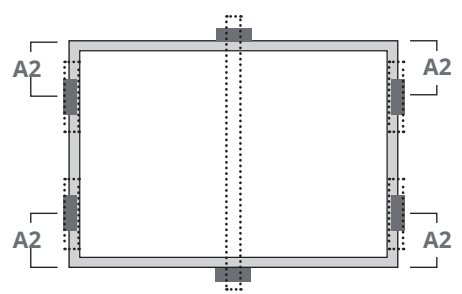

Use four clamps on the short side and two clamps on the long side. An additional support bar should be placed below the center of the module.

A2 range = (200 – 250) mm
 Maximum Load:
 Uplift load ≤ 2400 Pa
 Downforce load ≤ 5400 Pa

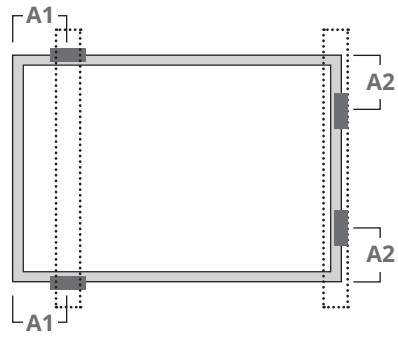

Use two clamps on the long side and two clamps on the short side.

A1 range = (300 – 550) mm
 A2 range = (200 – 250) mm
 Maximum Load:
 Uplift load ≤ 2400 Pa
 Downforce load ≤ 2400 Pa

CS6K-P, CS6K-M, CS6K-MS, CS6P-P and CS6P-M

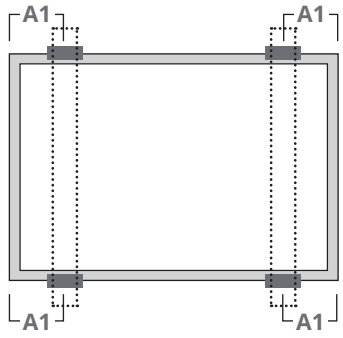

Use four clamps on the long side. Mounting rails run perpendicularly to the long side frame.

A1 range = (0 – 239) mm
Maximum Load:
Uplift load ≤ 2000 Pa
Downforce load ≤ 2000 Pa

A1 range = (240 – 550) mm
Maximum Load:
Uplift load ≤ 2400 Pa
Downforce load ≤ 2400 Pa

A1 range = (240 – 330) mm
Maximum Load:
Uplift load ≤ 2400 Pa
Downforce load ≤ 5400 Pa

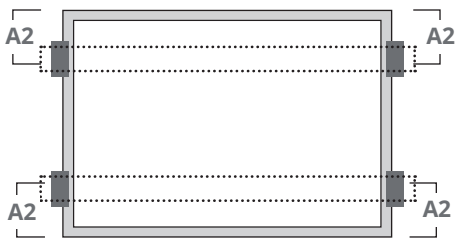

Use four clamps on the short side. Mounting rails run parallel to the long side frame.

A2 range = (200 – 250) mm
Maximum Load:
Uplift load ≤ 2400 Pa
Downforce load ≤ 2400 Pa



Use four clamps on the short side.

A2 range = (0 – 250) mm
Maximum Load:
Uplift load ≤ 2000 Pa
Downforce load < 2000 Pa

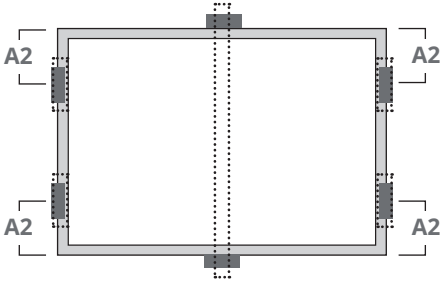

Use four clamps on the short side and two clamps on the long side. An additional support bar should be placed below the center of the module.

A2 range = (200 – 250) mm
Maximum Load:
Uplift load ≤ 2400 Pa
Downforce load ≤ 5400 Pa

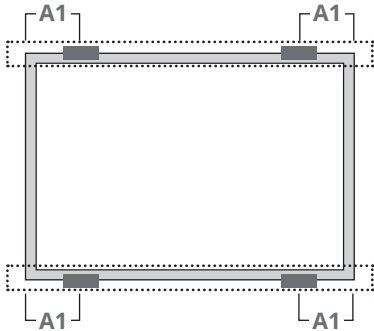

Use four clamps on the long side. Mounting rails run parallel to the long side frame.

A1 range = (240 – 330) mm
 Maximum Load:
 Uplift load \leq 2400 Pa
 Downforce load \leq 4000 Pa

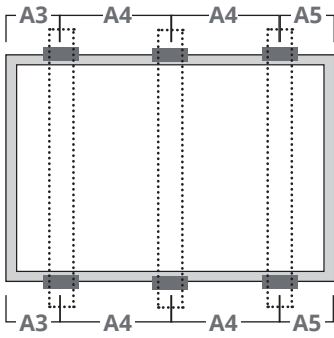

Use six clamps on the long side. Mounting rails run parallel to the short side frame.

A3 range = (80 – 280) mm, A5 range = (80 – 280) mm
 Maximum Load:
 Uplift load \leq 4000 Pa
 Downforce load \leq 6000 Pa

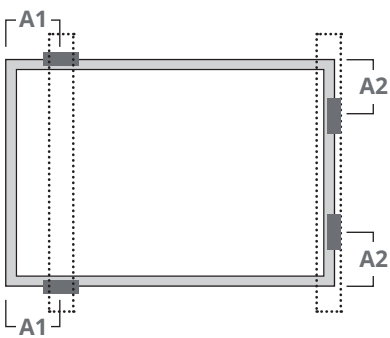

Use two clamps on the long side and two clamps on the short side.

A1 range = (100 – 550) mm
 A2 range = (200 – 250) mm
 Maximum Load:
 Uplift load \leq 2400 Pa
 Downforce load \leq 2400 Pa

Rail-less clamping for CS6K-P, CS6K-M and CS6K-MS

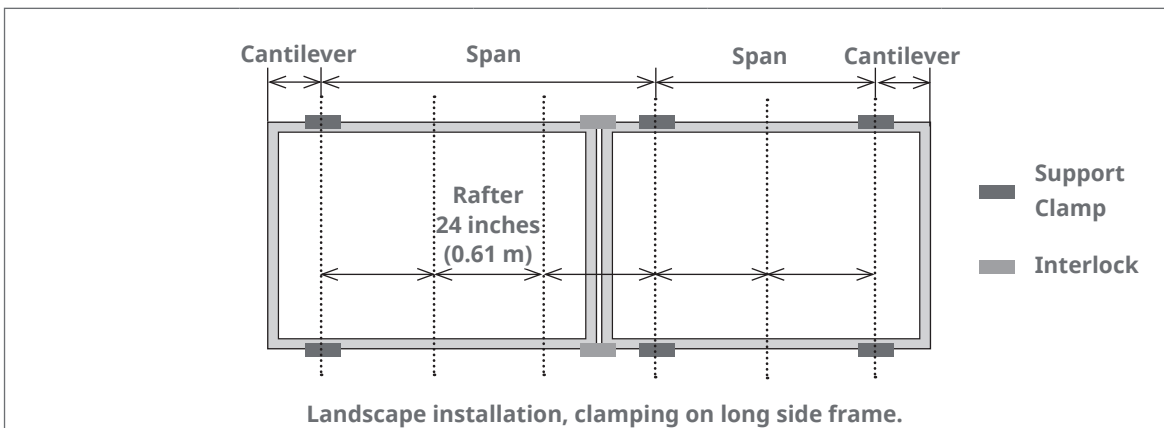

Landscape installation, clamping on long side frame.

Mounting Orientation	Max Span	Max Cantilever length	Downforce	Uplift
Landscape	72 inches (1.83 m)	24 inches (0.61 m)	2200 Pa	1400 Pa
	64 inches (1.63 m)	21.3 inches (0.54 m)	2400 Pa	1400 Pa
	48 inches (1.22 m)	16 inches (0.41 m)	3400 Pa	1800 Pa
	32 inches (0.81 m)	10.7 inches (0.27 m)	5400 Pa	2400 Pa

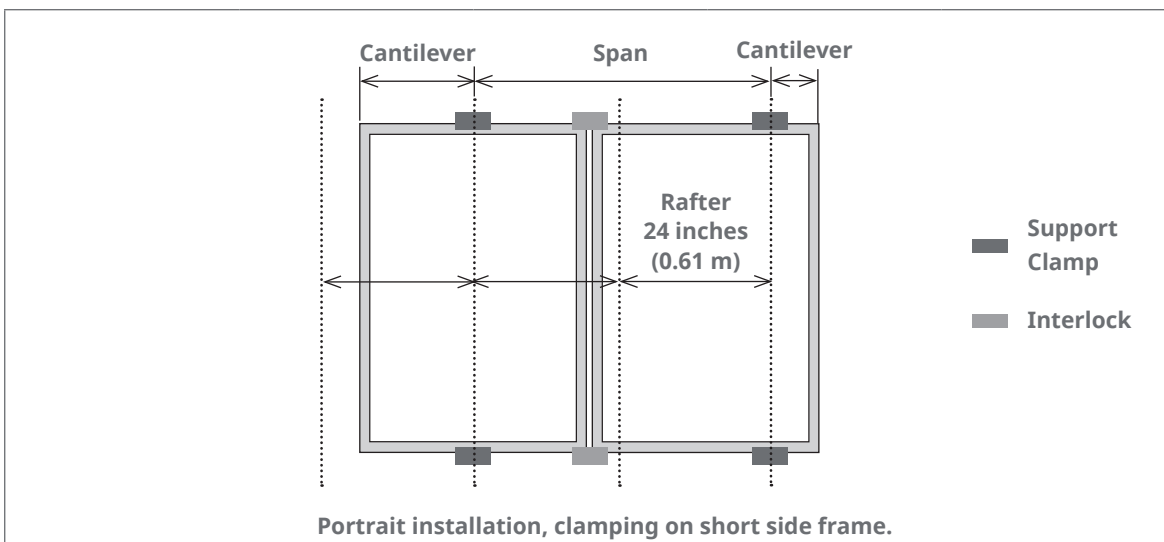

Portrait installation, clamping on short side frame.

Mounting Orientation	Max Span	Max Cantilever length	Downforce	Uplift
Portrait	48 inches (1.22 m)	16 inches (0.41 m)	2200 Pa	1200 Pa
	32 inches (0.81 m)	10.7 inches (0.27 m)	2200 Pa	1600 Pa
	24 inches (0.61 m)	8 inches (0.2 m)	2200 Pa	2200 Pa

CS6A-P, CS6A-M and CS6A-MS

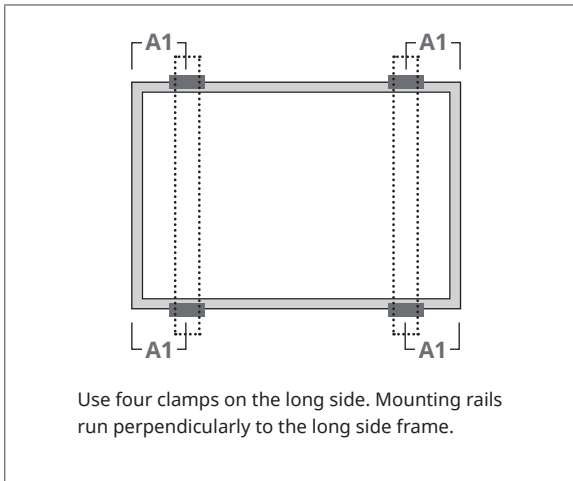

Use four clamps on the long side. Mounting rails run perpendicularly to the long side frame.

A1 range = (0 - 219) mm
 Maximum Load:
 Uplift load \leq 2000 Pa
 Downforce load \leq 2000 Pa

A1 range = (220 - 440) mm
 Maximum Load:
 Uplift load \leq 2400 Pa
 Downforce load \leq 2400 Pa

A1 range = (270 - 330) mm
 Maximum Load:
 Uplift load \leq 2400 Pa
 Downforce load \leq 5400 Pa

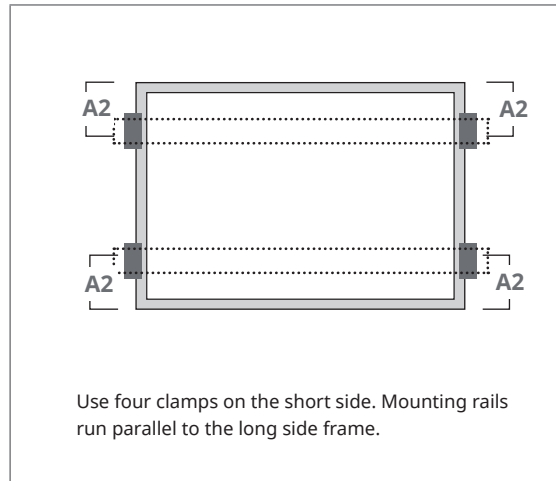

Use four clamps on the short side. Mounting rails run parallel to the long side frame.

A2 range = (200 - 250) mm
 Maximum Load:
 Uplift load \leq 2400 Pa
 Downforce load \leq 2400 Pa

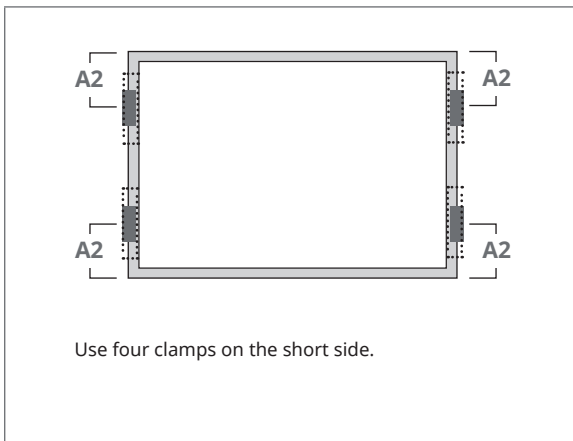

Use four clamps on the short side.

A2 range = (0 - 250) mm
 Maximum Load:
 Uplift load \leq 2400 Pa
 Downforce load \leq 2400 Pa

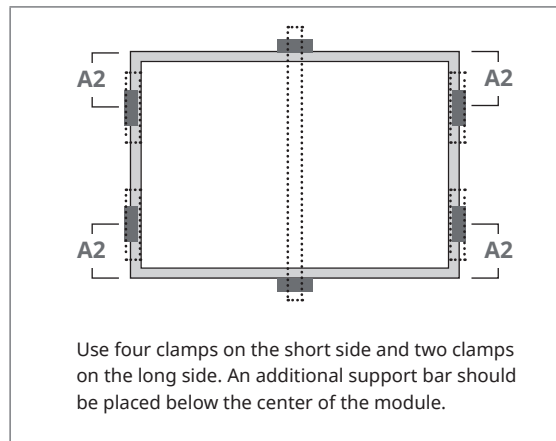

Use four clamps on the short side and two clamps on the long side. An additional support bar should be placed below the center of the module.

A2 range = (200 - 250) mm
 Maximum Load:
 Uplift load \leq 2400 Pa
 Downforce load \leq 5400 Pa

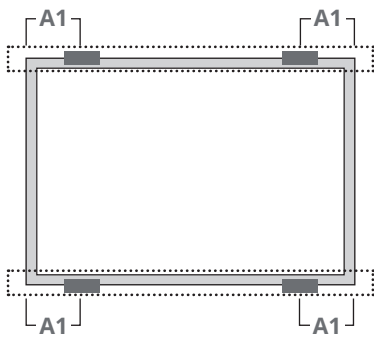

Use four clamps on the long side. Mounting rails run parallel to the long side frame.

A1 range = (270 – 330) mm
 Maximum Load:
 Uplift load ≤ 2400 Pa
 Downforce load ≤ 4000 Pa

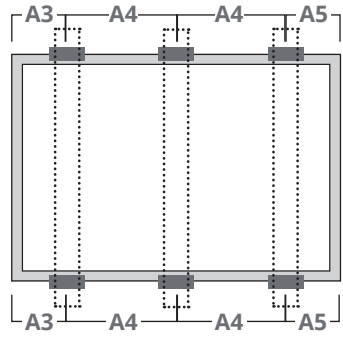

Use six clamps on the long side. Mounting rails run parallel to the short side frame.

A3 range = (80 – 380) mm
 A5 range = (80 – 380) mm
 Maximum Load:
 Uplift load ≤ 4000 Pa
 Downforce load ≤ 6000 Pa

CS6V-P, CS6V-M and CS6V-MS

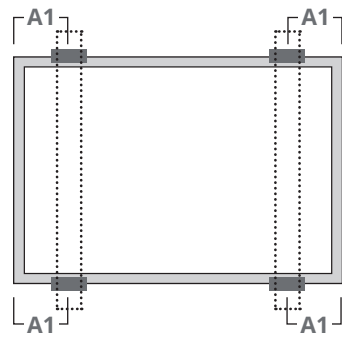

Use four clamps on the long side. Mounting rails run perpendicular to the long side frame.

A1 range = (0 – 239) mm
 Maximum Load:
 Uplift load ≤ 2000 Pa
 Downforce load ≤ 2000 Pa

A1 range = (240 – 550) mm
 Maximum Load:
 Uplift load ≤ 2400 Pa
 Downforce load ≤ 2400 Pa

A1 range = (240 – 330) mm
 Maximum Load:
 Uplift load ≤ 2400 Pa
 Downforce load ≤ 5400 Pa

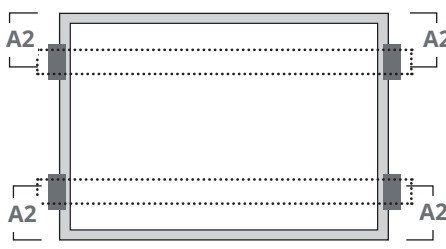

Use four clamps on the short side. Mounting rails run parallel to the long side frame.

A2 range = (170 – 210) mm
 Maximum Load:
 Uplift load ≤ 2400 Pa
 Downforce load ≤ 2400 Pa



Use four clamps on the short side.

A2 range = (0 - 210) mm
 Maximum Load:
 Uplift load \leq 2000 Pa
 Downforce load \leq 2000 Pa

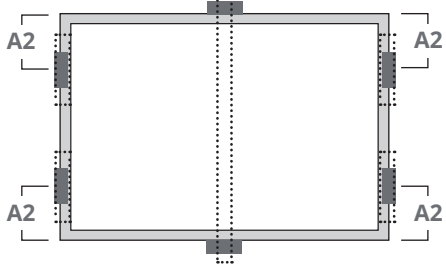

Use four clamps on the short side and two clamps on the long side. An additional support bar should be placed below the center of the module.

A2 range = (170 - 210) mm
 Maximum Load:
 Uplift load \leq 2400 Pa
 Downforce load \leq 5400 Pa

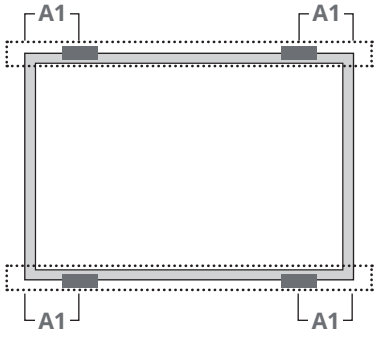

Use four clamps on the long side. Mounting rails run parallel to the long side frame.

A1 range = (240 - 330) mm
 Maximum Load:
 Uplift load \leq 2400 Pa
 Downforce load \leq 4000 Pa

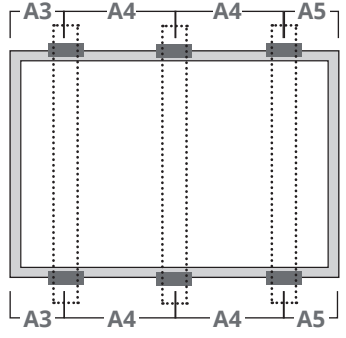

Use six clamps on the long side. Mounting rails run parallel to the short side frame.

A3 range = (80 - 380) mm
 A5 range = (80 - 380) mm
 Maximum Load:
 Uplift load \leq 4000 Pa
 Downforce load \leq 6000 Pa

MOUNTING METHOD B: INSERTION SYSTEMS

- The mounting method has been qualified by Canadian Solar Inc. and certified by VDE and CSA.
- Insertion methods can vary and depend on the mounting structures. The installer needs to follow the mounting guidelines recommended by the mounting system supplier. Each module must be securely maintained through all its length on two opposite sides. Install and tighten the insertion profiles to the support structure using the hardware and instructions provided by the mounting system manufacturer. The system designer and installer are solely responsible for load calculations and for the proper design of support structure.
- Canadian Solar Inc. warranty may be void in cases where improper insertion systems or unsuitable installation methods are found. When installing insertion profiles, please take the following measures into account:
 - ① Do not bend the module frame.
 - ② Do not touch the front glass or cast shadow onto it.
 - ③ Do not damage the surface of the frame.
 - ④ Ensure that the insertion profiles overlap the module frame by at least 10 mm (0.39 in).
 - ⑤ Ensure that the module frame (C-shape) overlaps the insertion profiles by at least 15 mm (0.59 in).
 - ⑥ Ensure insertion profile thickness and tolerances suit module thickness of 40 mm (1.57 in) modules.

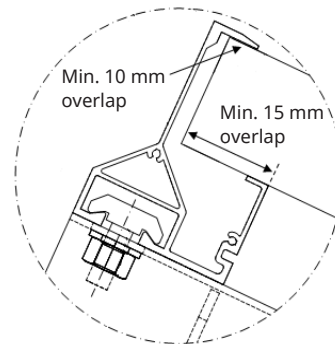

CS6X-P, CS6X-M, CS6U-P and CS6U-M

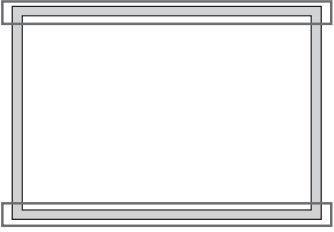

Use two insertion profiles running parallel to the long side frame.

Maximum Load:
Uplift load \leq 2400 Pa
Downforce load \leq 5400 Pa

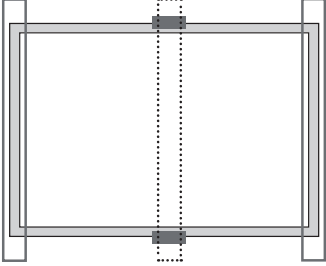

Use two insertion profiles running parallel to the short side frame. An additional support bar should be placed below the module. Use two clamps on the support bar.

Maximum Load:
Uplift load \leq 2400 Pa
Downforce load \leq 5400 Pa

CS6K-P, CS6K-M, CS6K-MS, CS6P-P, CS6P-M, CS6V-P, CS6V-M and CS6V-MS



Use two insertion profiles running parallel to the long side frame.

Maximum Load:
Uplift load \leq 2400 Pa
Downforce load \leq 4000 Pa



Use two insertion profiles running parallel to the short side frame.

Maximum Load:
Uplift load \leq 2000 Pa
Downforce load \leq 2000 Pa

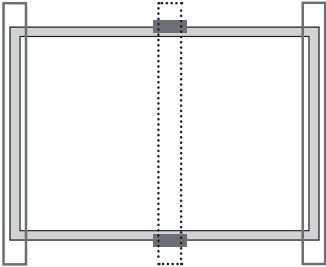

Use two insertion profiles running parallel to the short side frame. An additional support bar should be placed below the module. Use two clamps on the support bar.

Maximum Load:
Uplift load \leq 2400 Pa
Downforce load \leq 5400 Pa

CS6A-P, CS6A-M and CS6A-MS

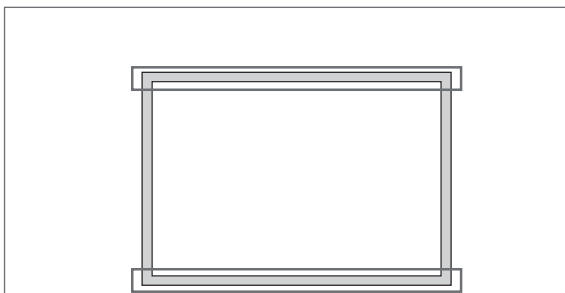

Use two insertion profiles running parallel to the long side frame.

Maximum Load:
Uplift load \leq 2400 Pa
Downforce load \leq 4000 Pa

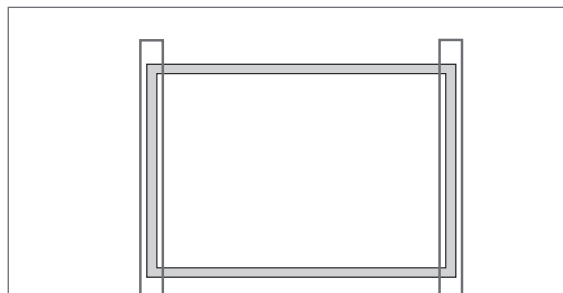

Use two insertion profiles running parallel to the short side frame.

Maximum Load:
Uplift load \leq 2400 Pa
Downforce load \leq 2400 Pa

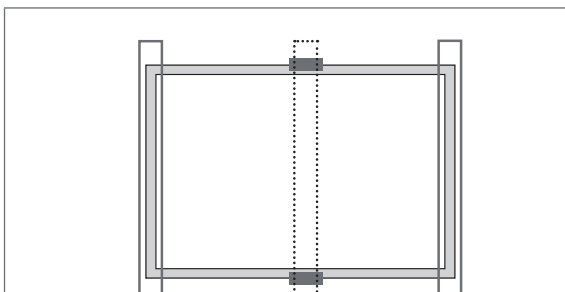

Use two insertion profiles running parallel to the short side frame. An additional support bar should be placed below the module. Use two clamps on the support bar.

Maximum Load:
Uplift load \leq 2400 Pa
Downforce load \leq 5400 Pa

**MOUNTING METHOD C:
CENTER MOUNTING METHOD WITH THIRD
PARTY TRACKER**

- Canadian Solar modules can be mounted with third party trackers as described below. All the requirements of the main manual and related tracker installation manual should apply to the tracker installation method. For detailed installation instructions, please refer to the related third party installation manual.
- The mounting method has been qualified by Canadian Solar Inc. and certified by VDE and CSA.

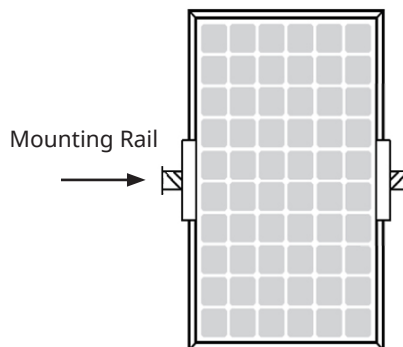

Module Type	Compatible Tracker	Mounting Hardware	Maximum Load (Pa)	Reference Manual (Version No.)
CS6P-xxxP	ATI DuraTrack™HZ Tracking System (V2.5)	12-inch length standard clamp (V2.5)	Uplift load ≤ 1200 Pa Downforce load ≤ 1200 Pa	DuraTrack™HZ Solar Tracker Installation Guide (November, 2012, Rev. B-01)
CS6U-xxxP, CS6U-xxxM, CS6X-xxxP and CS6P-xxxP	ATI DuraTrack™HZ Tracking System (V2.5)	12-inch length high-clearance clamp (V2.5)	Uplift load ≤ 2000 Pa Downforce load ≤ 2400 Pa	DuraTrack™HZ Solar Tracker Installation Guide (November 2012, Rev. B-01)
CS6X-xxxP, CS6U-xxxP and CS6U-xxxM	ATI DuraTrack™HZ Tracking System (V3)	Clamp Ear (V3)	Uplift load ≤ 2400 Pa Downforce load ≤ 2400 Pa	DuraTrack™HZ Solar Tracker Installation Guide (March 2015, Rev. A-02)
CS6U-xxxP and CS6U-xxxM	NEXTracker NX Horizon	400 mm Short Rail	Uplift load ≤ 2400 Pa Downforce load ≤ 2400 Pa	NEXTracker NX Horizon 2.1.1 Installation Manual (PDM-000002 Revision E, April 2016)

Please contact the tracker manufacturer and Canadian Solar Inc.'s technical support department for details in regard to specific projects.

ANNEX B: ALTERNATIVE GROUNDING METHODS

Canadian Solar modules can be grounded using third party grounding devices as described below. The grounding methods are certified by CSA according to UL 1703. All the basic requirements of the main installation manual should apply to the alternative grounding methods. For detailed grounding instructions, please refer to related third party installation manuals.

Method	Company	Grounding hardware	Compatible tracker	Reference Manual (Version No.)
A	Variety	Lay-in-Lug + Star Washer (UL 2703 & UL 467 certified)	Variety	Related reference installation manual
B	UNIRAC Inc.	UGC-1 grounding clips	SolarMount® rails	Unirac Code-Compliant Installation Manual (Pub 140130 -1cc)
C	Schletter GmbH	Schletter Rapid2+ Grounding Clamps	Schletter Rapid2+	Schletter Rapid2+ Clamp installation instructions
D	PanelClaw Inc.	Standard Claw (integrated grounding)	PanelClaw Grizzly Bear® FR Gen II mounting system	Grizzly Bear® FR Gen II Installation Manual (9910010 Rev A)
E	Array Technologies Inc.	ATI SS CLIPS & WEEB-ADC&WEEB-ADR	ATI Duratrack HZ Solar Tracker (V2.5)	WEEB installation instructions for ATI DuraTrack HZ mounting system only (50018785 RevC) from Burndy LLC & DuraTrack™HZ Solar Tracker Installation Guide (June 2014, Rev. B-02) from ATI
F	IronRidge Inc.	grounding mid clamps (integrated grounding)	standard (XRS) and light (XRL) rails	Standard (XRS) and Light (XRL) Rails with Integrated Grounding Installation Manual (2013 Edition v1.13)
G	Cosma International	WEEB-DPF grounding clips	Cosma/Magna top clamp mounting system	Ground Mount Racking Structure Assembly Instructions (V1.5_7196_CEC0022_02-21-2013)
H	DYNORAXX Inc.	DynoRaxx® DynoBond spring clips	-----	DynoRaxx® DynoBond Installation Manual (publication no 090413)
I	RBI Solar Inc.	Raised Zee purlin integrated with pre-punched grounding holes	RBI Solar Ground Mount System Model GM-I	Ground Mount System Model GM-I Module Installation Manual (14 April 2014, version 21)
J	Quick Rack PV Inc.	Clamp integrated with grounding pins	Quick Rack Rail-Free Mounting System	Quick Rack Rail-Free Mounting System for Composition/Asphalt Shingle Roofs Installation Manual (May 2014, Rev F)
K	Cantsink Mfg Inc.	1/4" serrated flange bolt & serrated flange nut	Brilliant Rack Ground Mount System	Brilliant Rack Ground Mount System Installation Manual (Revision 12/05/2014)
L	Everest Solar Systems, LLC	WEEB-KMC Clips	Crossrail 36, Crossrail 48 And Crossrail 80 Mounting Systems	WEEB Installation Instructions For Everest Solar Crossrail 36, Crossrail 48 And Crossrail 80 Mounting Systems Only (50015303 Rev H)
M	Unirac Inc.	Mid clamp retention teeth	SOLAR MOUNT (SM)	Solar Mount Installation Guide (Revision PUB15MAR02)
N	Sunlink Inc.	Center Clamps & End Clamps with pre-punched teeth	Ballasted Ground Mount System and Core Roof Mount System	Assembly Instructions for Core RMS (Rev 03-14-2014) and Assembly Instructions for Ballasted GMS (Rev 02/02/2014)
O	Roof Tech Inc.	Bonding Plate	RT-[E] Mount E Mount AIR	RT-[E] Mount E Mount AIR Installation Manual (March 2015)
P	NEXTracker Inc.	4111-8 Bobtail Collar and 4110-8 Bobtail Pin	NEXTracker 120 Solar Tracker.	NEXTrackerSPT Installation Manual (March 2015)
Q	BURNDY LLC.	WEEB-UIR and WEEB-11.5	RBI Solar Groundmount	WEEB Installation Instructions For RBI Solar Groundmount Only (104-0404-000074-003)

ANNEX C: MECHANICAL AND ELECTRICAL RATINGS

Standard Test Conditions are: Irradiance of 1000 W/m², AM1.5 spectrum, and cell temperature of 25°C. The electrical characteristics are respectively within ±10% or [0; +5 W] of the indicated values for Isc, Voc and Pmax. Specifications are subject to change without notice.

Table 1: Mechanical And Electrical Ratings under STC

Module Type	Maximum Power Pmax <W>	Operating voltage Vmp <V>	Operating current Imp <A>	Open Circuit Voltage Voc <V>	Short Circuit Current Isc <A>	Max. Series Fuse Rating <A>	Overall Dimension <mm>	Weight <kg>
CS6P-245M	245.0	30.3	8.09	37.4	8.61	15.00	1638 x 982 x 40 (64.5 x 38.7 x 1.57 in)	18.0 (39.7 lbs)
CS6P-250M	250.0	30.4	8.22	37.5	8.74	15.00		
CS6P-255M	255.0	30.5	8.35	37.7	8.87	15.00		
CS6P-260M	260.0	30.7	8.48	37.8	8.99	15.00		
CS6P-265M	265.0	30.9	8.61	37.9	9.11	15.00		
CS6P-270M	270.0	31.1	8.67	38.2	9.19	15.00		
CS6P-275M	275.0	31.3	8.80	38.3	9.31	15.00		
CS6P-280M	280.0	31.5	8.89	38.5	9.43	15.00		
CS6P-285M	285.0	31.7	8.98	38.6	9.51	15.00		
CS6P-290M	290.0	31.9	9.09	38.7	9.59	15.00		
CS6P-240P	240.0	29.9	8.03	37.0	8.59	15.00	1638 x 982 x 40 (64.5 x 38.7 x 1.57 in)	18.0 (39.7 lbs)
CS6P-245P	245.0	30.0	8.17	37.1	8.74	15.00		
CS6P-250P	250.0	30.1	8.30	37.2	8.87	15.00		
CS6P-255P	255.0	30.2	8.43	37.4	9.00	15.00		
CS6P-260P	260.0	30.4	8.56	37.5	9.12	15.00		
CS6P-265P	265.0	30.6	8.66	37.7	9.23	15.00		
CS6P-270P	270.0	30.8	8.75	37.9	9.32	15.00		
CS6P-275P	275.0	31.0	8.88	38.0	9.45	15.00		
CS6P-280P	280.0	31.3	8.95	38.2	9.52	15.00		
CS6P-285P	285.0	31.4	9.06	38.3	9.64	15.00		
CS6A-195M	195.0	24.2	8.04	29.9	8.56	15.00	1324 x 984 x 40 (52.1 x 38.7 x 1.57 in)	15.5 (34.2 lbs)
CS6A-200M	200.0	24.3	8.22	30.0	8.74	15.00		
CS6A-205M	205.0	24.5	8.38	30.2	8.90	15.00		
CS6A-210M	210.0	24.6	8.54	30.3	9.06	15.00		
CS6A-215M	215.0	24.7	8.70	30.4	9.22	15.00		
CS6A-220M	220.0	24.8	8.87	30.6	9.31	15.00		
CS6A-205MS	205.0	24.5	8.37	30.6	9.21	15.00		
CS6A-210MS	210.0	24.7	8.50	30.8	9.29	15.00		
CS6A-215MS	215.0	24.9	8.63	31.0	9.37	15.00		
CS6A-220MS	220.0	25.1	8.76	31.2	9.45	15.00		
CS6A-225MS	225.0	25.3	8.91	31.4	9.53	15.00		

Module Type	Maximum Power Pmax <W>	Operating voltage Vmp <V>	Operating current Imp <A>	Open Circuit Voltage Voc <V>	Short Circuit Current Isc <A>	Max. Series Fuse Rating <A>	Overall Dimension <mm>	Weight <kg>		
CS6A-230MS	230.0	25.5	9.02	31.6	9.61	15.00				
CS6A-235MS	235.0	25.7	9.14	31.8	9.68	15.00				
CS6A-240MS	240.0	25.9	9.27	32.0	9.76	15.00				
CS6A-245MS	245.0	26.1	9.39	32.2	9.84	15.00				
CS6A-195P	195.0	24.0	8.13	29.6	8.69	15.00	1324 x 984 x 40 (52.1 x 38.7 x 1.57 in)	15.5 (34.2 lbs)		
CS6A-200P	200.0	24.1	8.30	29.8	8.87	15.00				
CS6A-205P	205.0	24.2	8.47	29.9	9.03	15.00				
CS6A-210P	210.0	24.3	8.63	30.0	9.19	15.00				
CS6A-215P	215.0	24.5	8.78	30.2	9.35	15.00				
CS6A-220P	220.0	24.6	8.95	30.4	9.45	15.00				
CS6X-290P	290.0	35.9	8.08	44.4	8.64	15.00			1954 x 982 x 40 (76.9 x 38.7 x 1.57 in)	22.00 (48.5 lbs) (3.2mm Glass)
CS6X-295P	295.0	36.0	8.19	44.5	8.76	15.00				
CS6X-300P	300.0	36.1	8.30	44.6	8.87	15.00				
CS6X-305P	305.0	36.3	8.41	44.8	8.97	15.00				
CS6X-310P	310.0	36.4	8.52	44.9	9.08	15.00				
CS6X-315P	315.0	36.6	8.61	45.1	9.18	15.00				
CS6X-320P	320.0	36.8	8.69	45.3	9.26	15.00				
CS6X-325P	325.0	37.0	8.78	45.5	9.34	15.00				
CS6X-330P	330.0	37.2	8.88	45.6	9.45	15.00				
CS6X-335P	335.0	37.4	8.96	45.8	9.54	15.00				
CS6X-340P	340.0	37.6	9.05	45.9	9.62	15.00				
CS6X-345P	345.0	37.8	9.13	46.0	9.69	15.00				
CS6X-350P	350.0	38.1	9.21	46.2	9.79	15.00				
CS6V-200M	200.0	25.2	7.95	31.1	8.46	15.00	1638 x 826 x 40 (64.5 x 32.5 x 1.57 in)	16.0 (35.3 lbs)		
CS6V-205M	205.0	25.3	8.11	31.2	8.63	15.00				
CS6V-210M	210.0	25.4	8.27	31.3	8.79	15.00				
CS6V-215M	215.0	25.5	8.43	31.5	8.94	15.00				
CS6V-220M	220.0	25.7	8.56	31.6	9.08	15.00				
CS6V-225M	225.0	26.0	8.67	31.8	9.19	15.00				
CS6V-230M	230.0	26.1	8.81	31.9	9.33	15.00				
CS6V-235M	235.0	26.4	8.91	32.1	9.45	15.00				
CS6V-240M	240.0	26.7	9.00	32.2	9.55	15.00				
CS6V-245M	245.0	27.0	9.09	32.4	9.66	15.00				
CS6V-210MS	210.0	25.4	8.27	31.5	9.19	15.00				
CS6V-215MS	215.0	25.6	8.40	31.7	9.27	15.00				
CS6V-220MS	220.0	25.8	8.53	31.9	9.35	15.00				
CS6V-225MS	225.0	26.0	8.66	32.1	9.43	15.00				
CS6V-230MS	230.0	26.2	8.78	32.3	9.51	15.00				
CS6V-235MS	235.0	26.4	8.91	32.5	9.59	15.00				
CS6V-240MS	240.0	26.6	9.03	32.7	9.67	15.00				
CS6V-245MS	245.0	26.8	9.15	32.9	9.75	15.00				
CS6V-250MS	250.0	27.0	9.26	33.1	9.83	15.00				
CS6V-255MS	255.0	27.2	9.38	33.3	9.91	15.00				
CS6VH-115MS	115.0	13.1	8.78	16.2	9.59	15.00			844 x 826 x 40	9.0
CS6VH-120MS	120.0	13.3	9.03	16.4	9.67	15.00			(33.2 x 32.5 x 1.57 in)	(19.8 lbs)

Module Type	Maximum Power Pmax <W>	Operating voltage Vmp <V>	Operating current Imp <A>	Open Circuit Voltage Voc <V>	Short Circuit Current Isc <A>	Max. Series Fuse Rating <A>	Overall Dimension <mm>	Weight <kg>
CS6VH-125MS	125.0	13.5	9.26	16.6	9.75	15.00		
CS6V-190P	190.0	24.6	7.73	30.6	8.28	15.00	1638 × 826 × 40 (64.5 × 32.5 × 1.57 in)	16.0 (35.3 lbs)
CS6V-195P	195.0	24.8	7.87	30.7	8.44	15.00		
CS6V-200P	200.0	24.9	8.03	30.8	8.59	15.00		
CS6V-205P	205.0	25.0	8.19	30.9	8.76	15.00		
CS6V-210P	210.0	25.1	8.35	31.1	8.92	15.00		
CS6V-215P	215.0	25.3	8.51	31.2	9.07	15.00		
CS6V-220P	220.0	25.5	8.64	31.4	9.21	15.00		
CS6V-225P	225.0	25.7	8.75	31.6	9.32	15.00		
CS6V-230P	230.0	25.9	8.90	31.7	9.47	15.00		
CS6V-235P	235.0	26.1	8.99	31.8	9.58	15.00		
CS6V-220P	220.0	25.5	8.64	31.4	9.21	15.00		
CS6V-225P	225.0	25.7	8.75	31.6	9.32	15.00		
CS6V-230P	230.0	25.9	8.90	31.7	9.47	15.00		
CS6V-235P	235.0	26.1	8.99	31.8	9.58	15.00		
CS6K-240P	240.0	29.9	8.03	37.0	8.59	15.00	1650 × 992 × 40 (65.0 × 39.1 × 1.57 in)	18.2 (40.1 lbs)
CS6K-245P	245.0	30.0	8.17	37.1	8.74	15.00		
CS6K-250P	250.0	30.1	8.30	37.2	8.87	15.00		
CS6K-255P	255.0	30.2	8.43	37.4	9.00	15.00		
CS6K-260P	260.0	30.4	8.56	37.5	9.12	15.00		
CS6K-265P	265.0	30.6	8.66	37.7	9.23	15.00		
CS6K-270P	270.0	30.8	8.75	37.9	9.32	15.00		
CS6K-275P	275.0	31.0	8.88	38.0	9.45	15.00		
CS6K-280P	280.0	31.3	8.95	38.2	9.52	15.00		
CS6K-285P	285.0	31.4	9.06	38.3	9.64	15.00		
CS6K-250M	250.0	30.4	8.22	37.5	8.74	15.00	1650 × 992 × 40 (65.0 × 39.1 × 1.57 in)	18.2 (40.1 lbs)
CS6K-255M	255.0	30.5	8.35	37.7	8.87	15.00		
CS6K-260M	260.0	30.7	8.48	37.8	8.99	15.00		
CS6K-265M	265.0	30.9	8.61	37.9	9.11	15.00		
CS6K-270M	270.0	31.1	8.67	38.2	9.19	15.00		
CS6K-275M	275.0	31.3	8.80	38.3	9.31	15.00		
CS6K-280M	280.0	31.5	8.89	38.5	9.43	15.00		
CS6K-285M	285.0	31.7	8.98	38.6	9.51	15.00		
CS6K-290M	290.0	31.9	9.09	38.7	9.59	15.00		
CS6K-255MS	255.0	30.7	8.31	37.9	9.11	15.00		
CS6K-260MS	260.0	30.9	8.42	38.1	9.19	15.00		
CS6K-265MS	265.0	31.1	8.53	38.3	9.27	15.00		
CS6K-270MS	270.0	31.3	8.63	38.5	9.35	15.00		
CS6K-275MS	275.0	31.5	8.74	38.7	9.43	15.00		
CS6K-280MS	280.0	31.7	8.84	38.9	9.51	15.00		
CS6K-285MS	285.0	31.9	8.94	39.1	9.59	15.00		
CS6K-290MS	290.0	32.1	9.05	39.3	9.67	15.00		
CS6K-295MS	295.0	32.3	9.14	39.5	9.75	15.00		
CS6K-300MS	300.0	32.5	9.24	39.7	9.83	15.00		
CS6K-305MS	305.0	32.7	9.33	39.9	9.91	15.00		

Module Type	Maximum Power P _{max} <W>	Operating voltage V _{mp} <V>	Operating current I _{mp} <A>	Open Circuit Voltage Voc <V>	Short Circuit Current I _{sc} <A>	Max. Series Fuse Rating <A>	Overall Dimension <mm>	Weight <kg>
CS6U-290P	290.0	35.9	8.08	44.4	8.64	15.00	1960 × 992 × 40 (77.2 × 39.1 × 1.57 in)	22.4 (49.4 lbs)
CS6U-295P	295.0	36.0	8.19	44.5	8.76	15.00		
CS6U-300P	300.0	36.1	8.30	44.6	8.87	15.00		
CS6U-305P	305.0	36.3	8.41	44.8	8.97	15.00		
CS6U-310P	310.0	36.4	8.52	44.9	9.08	15.00		
CS6U-315P	315.0	36.6	8.61	45.1	9.18	15.00		
CS6U-320P	320.0	36.8	8.69	45.3	9.26	15.00		
CS6U-325P	325.0	37.0	8.78	45.5	9.34	15.00		
CS6U-330P	330.0	37.2	8.88	45.6	9.45	15.00		
CS6U-335P	335.0	37.4	8.96	45.8	9.54	15.00		
CS6U-340P	340.0	37.6	9.05	45.9	9.62	15.00		
CS6U-345P	345.0	37.8	9.13	46.0	9.69	15.00		
CS6U-350P	350.0	38.1	9.21	46.2	9.79	15.00		
CS6U-290M	290.0	36.3	8.00	44.7	8.51	15.00	1960 × 992 × 40 (77.2 × 39.1 × 1.57 in)	22.4 (49.4 lbs)
CS6U-295M	295.0	36.4	8.11	44.9	8.63	15.00		
CS6U-300M	300.0	36.5	8.22	45	8.74	15.00		
CS6U-305M	305.0	36.6	8.33	45.2	8.84	15.00		
CS6U-310M	310.0	36.7	8.44	45.3	8.95	15.00		
CS6U-315M	315.0	36.9	8.53	45.5	9.04	15.00		
CS6U-320M	320.0	37.2	8.61	45.6	9.13	15.00		
CS6U-325M	325.0	37.4	8.69	45.8	9.21	15.00		
CS6U-330M	330.0	37.5	8.8	45.9	9.31	15.00		
CS6U-335M	335.0	37.8	8.87	46.1	9.41	15.00		
CS6U-340M	340.0	37.9	8.97	46.2	9.48	15.00		
CS6U-345M	345.0	38.1	9.06	46.4	9.56	15.00		
CS6U-350M	350.0	38.3	9.14	46.6	9.67	15.00		

ANNEX D: MODULE CLEANING GUIDELINE

This manual covers requirements for the cleaning procedure of Canadian Solar Inc. photovoltaic modules. The purpose of these cleaning guidelines is to provide general information for cleaning Canadian Solar modules. Professional installers should read these guidelines carefully and strictly follow these instructions.

Failure to follow these instructions may result in death, injury or property damage to the photovoltaic module. Damages induced by inappropriate cleaning procedures will void Canadian Solar's warranty.



SAFETY WARNING

- Cleaning activities create risk of damaging the modules and array components, as well as increasing the potential electric shock hazard.
- Cracked or broken modules represent an electric shock hazard due to leakage currents, and the risk of shock is increased when modules are wet. Before cleaning, thoroughly inspect modules for cracks, damage, and loose connections.

- The voltage and current present in an array during daylight hours are sufficient to cause a lethal electrical shock.
- Ensure that the circuit is disconnected before starting the cleaning procedure as contact with leakage of electrically active parts can result in injury.
- Ensure that the array has been disconnected from other active components (such as inverter or combiner boxes) before starting with the cleaning.
- Wear suitable protection (clothes, insulated gloves, etc.).
- **Do not** immerse the module, partially or totally, in water or any other cleaning solution.

HANDLING NOTICE

- Use a proper cleaning solution and suitable cleaning equipment.
- **Do not** use abrasive or electric cleaners on the module.
- Particular attention should be taken to avoid the module backsheet or frame to come in contact with sharp objects, as scratches may directly affect product safety.
- **Do not** use de-greasers on the module.
- **Do not** use cleaning corrosive solutions containing acid, alkali, acetone, or industrial alcohol.
- Canadian Solar Inc. recommends to avoid rotating brush cleaning method, as it can lead to the formation of micro cracks.
- Dirt must never be scraped or rubbed away when dry, as this will cause micro-scratches on the glass surface.

OPERATION PREPARATION

- Noticeable dirt must be rubbed away by gentle cleaning-implement (soft cloth, sponge or brush with soft bristles).

- Ensure that brushes or agitating tools are not abrasive to glass, EPDM, silicone, aluminum, or steel.
- Conduct the cleaning activities avoiding the hottest hours of the day, in order to avoid thermal stress on the module.

We recommend the following to be used:

- Water with low mineral content
- Near neutral pH water
- The maximum water pressure recommended is 4 MPa (40 bar)

CLEANING METHODS

Method A: Compressed Air

Canadian Solar Inc. recommends cleaning the soft dirt (like dust) on modules just with compressed air. This technique can be applied as long as the method is efficient enough considering the existing conditions.

Method B: Wet cleaning

If excessive soiling is present on the module surface, a non-conductive brush, sponge, or other mild agitating method may be used with caution.

- Ensure that any brushes or agitating tools are constructed with non-conductive materials to minimize risk of electric shock and that they are not abrasive to the glass or the aluminum frame.
- If grease is present, an environmentally friendly cleaning agent may be used with caution.

AMENDMENT EDITIONS AND DATES

- Rev A1 is released in April, 2014.
- Rev A2 is released in December, 2014
- Rev A3 is released in August, 2015
- Rev A4 is released in March, 2016
- Rev A5 is released in June, 2016
- Rev A6 is released in December, 2016
- Rev A7 is released in March, 2017

INSTALLATION MANUAL DISCLAIMER

The information contained in this manual is subject to change by Canadian Solar Inc. without prior notice. Canadian Solar Inc. gives no warranty of any kind whatsoever, either explicitly or implicitly, with respect to the information contained herein.

This Manual (or document) is written in English with Chinese (or other language) translation for reference only. In case there are inconsistencies or conflicts between the English version and the Chinese version (or other language version) of this Manual (or document), the English version shall prevail and take control in all respects.

CANADIAN SOLAR INC.

545 Speedvale Avenue West, Guelph, Ontario, Canada N1K 1E6

www.canadiansolar.com